

Encoder-Kit L

Components for Linear Measurement

ATTENTION

Observe precautions for
handling electrostatic
discharge sensitive
devices



Mounting Instructions

Contents

1	Notes on safety	4		
1.1	General information	4		
1.2	Directives on instrument safety and electromagnetic compatibility (EMC)	4		
1.3	Transport, storage, unpacking	4		
1.4	Notes on use	5		
1.5	Notes on maintenance	5		
2	Delivery specification	7		
3	Instructions on use	7		
4	Design	8		
5	Installation	9		
5.1	Installation conditions	9		
	<i>Installation position</i>	9		
	<i>Counting direction</i>	10		
	<i>Cable, Extension cable</i>	10		
	<i>Electromagnetic compatibility (EMC)</i>	11		
	<i>Connectors, pin assignment</i>	12		
	<i>Recommended connection circuits</i>	16		
5.2	Installation of scale tape without using guide tapes	19		
5.2.1	Requirements	19		
5.2.2	Mounting the DOUBLEFLEX scale tapes (as per MV10... ordering key)	19		
5.2.3	Mounting the SINGLEFLEX scale tapes (as per MV11... ordering key)	21		
5.3	Installation of scale tape using guide tapes (as per MV12 ...MV13 ordering key)	23		
5.3.1	Requirements	23		
5.3.2	Mounting the guide tapes	23		
5.3.3	Mounting the DOUBLEFLEX tapes	24		
5.3.4	Mounting the SINGLEFLEX tapes	26		
5.4	Mounting the EPIFLEX measuring module	29		
6	Technical specification	42		
	<i>Resolution and accuracy (definition)</i>	42		
	<i>Mechanical data</i>	43		
	<i>Electrical data</i>	45		
	<i>Ambient conditions</i>	45		
7	Ordering key	46		

1 Notes on safety

1.1 General information

Make sure to familiarize yourself thoroughly with the contents of these installation instructions before installing and starting up the Encoder Kit L. On request, our service department or authorized dealers will provide you with supplementary information.

Please refer to the relevant operating instructions for the functions of the Encoder Kit L in conjunction with auxiliary electronic units, counters, displays and controls, and the fundamental mechanical instruments such as processing machines, measuring instruments, etc.



Observe notes and warnings in text!

1.2 Directives on instrument safety and electromagnetic compatibility (EMC)

The Encoder Kit L conforms to relevant regulations for technical equipment (Legislation on Product Safety), revision 1992.10.23 and the appropriate rules for the prevention of accidents.

The manufacturer is responsible for compliance of the overall system including the basic mechanical unit, the measuring system and the additional electric units, with the directives of the Legislation on Product Safety.

The same applies to the EMC regulations.

The measuring system meets the safety requirements for electrical measuring systems, control devices, control apparatus and laboratory instruments IEC 1010-1.

The way the EPIFLEX module is designed - optoelectronic function elements on a glass substrate with ceramic cover - it is not immune against electromagnetic radiation.

As the Encoder Kit L is installed in a larger function group, the user is responsible for taking the necessary measures to ensure and prove the EMC electromagnetic compatibility.

See also chapter 5.1 *Electromagnetic compatibility*

The Encoder Kit L as described in this documentation conforms to EC regulations and is marked with the CE label.

1.3 Transport, storage unpacking

The Encoder Kit L may only be transported in its original packing. The same is recommended for storage. This applies in particular for the DOUBLEFLEX scale tapes. Always use the original packing for the transport of the DOUBLEFLEX tapes:

Lengths up to ~ 3 m ⇒ laid out straight;
Lengths exceeding 3 m ⇒ laid out in an „eight“ -shape



Caution!

Never store, transport or handle the DOUBLEFLEX scale tape while rolled up.

SINGLEFLEX scale tapes may be rolled up with a minimum curvature radius of 140 mm. No restrictions apply to the length.

Handling the DOUBLEFLEX scale tape:

The great metrological benefits of the DOUBLEFLEX tape are a result of the adhesive layer between the scale tape and the carrier tape.

To make sure that this layer is not impaired, observe the following:

- Only remove the DOUBLEFLEX type from its packing at the site of installation and immediately prior to installation
- Do not separate the scale tape from the carrier tape
- Also make sure that the scale and the carrier tape are not inadvertently separated, particularly at the ends
- Handle the DOUBLEFLEX tape in such a way that the bending does not exceed 100 mm and the unsupported length between two supporting points 800 mm.
Tapes with a length up to 1200 mm must be supported about 300 mm from each end, longer ones in several points
- Avoid cross- and lengthwise displacements between the scale tape and the carrier tape



Caution!

In case of a transverse shifting (for example caused by transportation) of the carrier tape to the grating tape a correction is possible by a (*only*) lateral force.

Before assembling the carrier and grating tape have to flush together over the whole length.

On the other hand there is the danger of lifting the grating tape from the carrier tape during the mounting into the mounting groove.

In case of unintentional lift off the ends of the grating tape from the carrier tape the complete DOUBLEFLEX scale is to send back to the producer for restoration the adhesive layer.

1.4 Notes on use

- Comply with applicable pin assignment if auxiliary electronic units are connected (counter, displays, controls)
- Use the Encoder Kit L only with the supply voltage described in the installation instructions
- **Disconnect voltage supply before connecting or disconnecting plugs**
- Integrate the Encoder Kit L in instruments, machines or devices in such a way that it is protected against contamination
- Protect the scale against mechanical damage
- Protect the EPIFLEX measuring module and the connector board against shock, impact and humidity; they contain electronic units

1.5 Notes on maintenance

Modifications and repairs of this Encoder Kit L may only be carried out by the manufacturer or appropriately authorized persons. The manufacturer is not liable for damages caused by unauthorized handling of the Encoder Kit L. All warranty claims are forfeited by unauthorized handling.

Encoder Kit L

The Encoder Kit L requires no maintenance whatsoever. Open measuring systems are sensitive to contamination and must therefore be protected against dirt by way of a suitable construction by the user.

The graduation of the scale tape (tape surface) and the side of the EPIFLEX measuring module (scanning window) facing the scale tape are in special need of protection.

They are particularly sensitive to rough and irregular contamination and deposits (e.g. oil, grease, water).

Depending on the position in which the system has been installed and the ambient condition, it may be necessary to clean the tape surface or scanning window of the EPIFLEX measuring module from time to time.

If the monitoring signal output by the EPIFLEX measuring module is used, a cleaning request is displayed.

When cleaning the components, make sure that the EPIFLEX measuring module and the scale are not scratched by any deposited particles. Dirt should be removed using a soft brush or oil-free compressed air. For subsequent cleaning, cotton wool or a soft cloth are ideal, for tenacious stains use acetone or methylated spirit.



Caution!

Acetone and methylated spirit are inflammable.

DOUBLEFLEX scale tape

- When cleaning the DOUBLEFLEX scale tape, make sure to always wipe it lengthwise. If the tape is wiped crosswise, the scale tape may be displaced with respect to the carrier tape, resulting in impaired measuring functions of the Encoder Kit L.
- When using solvent, make sure that this cannot flow under the scale tape.
In the DOUBLEFLEX tape, solvent may destroy the adhesive layer between the scale tape and the carrier tape and cause the scale tape to lift off.
- If the adhesive tape comes into contact with solvent, the adhesive agent may start to dissolve, reducing the adhesive power.

2 Delivery specification

Standard version

- EPIFLEX measuring module according to ordering specification (see ordering key)
- Connector board according to ordering specification
- Connecting cable according to ordering specification (see ordering key)
- DOUBLEFLEX scale tape according to ordering specification (see ordering key) **or**
- SINGLEFLEX scale tape according to ordering specification (see ordering key)
- 2 spacer films for installing the EPIFLEX measuring module (marking: 20 pcs. or 100 pcs., depending on graduation period)
- Installation instructions
- Packing

Optional

- Guide tape for DOUBLEFLEX scale tape, recommended for lengths exceeding 300 mm
- Guide tape for SINGLEFLEX scale tape
- FAV guide tape mounting device
- Extension cable

3 Instructions on use

The Encoder Kit L is a minimum configuration of an open reflected-light length-measuring system. It is ideal for installation in systems with confined space, where high resolution and accuracy is required, such as:

- Plotter
- Printer
- Instruments in reprographics
- Probes
- Robots
- X/Y-stages
- Medical systems

The EPIFLEX measuring module is available in two versions:

- with one-field sensor (EML- 4)
- with two-field sensor (EML- 5)

Both versions feature the same dimensions and identical signal interfaces.

The EPIFLEX measuring module with two-field sensor is less sensitive to contamination than that with one-field sensor.

Required scale tape lengths:

- | | |
|--------|--|
| EML- 4 | tape length = measuring length + 21 mm |
| EML- 5 | tape length = measuring length + 30 mm |

4 Design

Dimensional standard
conforming to
ordering key MV...



EPIFLEX measuring module
conforming to
ordering key EML...

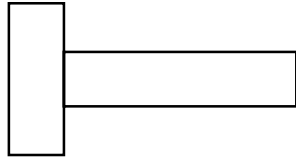

Connector board
conforming to
ordering key ALP ...



Connecting cable
conforming to
ordering key Kab ...

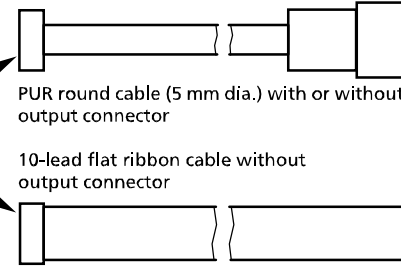

Output signal measuring module/input signal connector board	Interpolation	Output signal connector board
Sinus 11 μA_{pp}	5x	RS 422 A
	10x	RS 422 A
	25x	RS 422 A
	50x	RS 422 A
Sinus 1 V_{pp}	none	Sinus 11 μA_{pp}
	none	Sinus 1 V_{pp}
	none	RS 422 A

Fig. 1: Encoder Kit L - modular design

The Encoder Kit L is a minimum configuration of an open reflected-light measuring system.

It consists of the dimensional standard (preferably steel tape), the EPIFLEX measuring module, the connector board ALP and the connecting cable.

The scale tape is scanned electronically by the EPIFLEX measuring module in reflected light.

5 Installation

5.1 Installation conditions

Installation position

The Encoder Kit L can be installed in any position.

However, to eliminate the possibility of marked contamination it should be installed so that the graduation of the scale tape is in a vertical position.

Adopt suitable designing measures to

- prevent dirt and particles settling on the Encoder Kit L during use;
- install the Encoder Kit L so that the graduated surface and the scanning window of the EPIFLEX measuring module are easily accessible for cleaning.

Preferably, the tape should be mounted in a groove or along an edge:

- The grooves or edges serve as an installation orientation for straight mounting of the tapes, particularly very long ones.
- For the DOUBLEFLEX scale tape, they also serve as a stop to prevent any displacement between the scale tape and the carrier tape.

If the design does not provide grooves or edges (e.g. when mounting the scale tape on granite surfaces), flexible tape PCBs can be used which are available as an option.

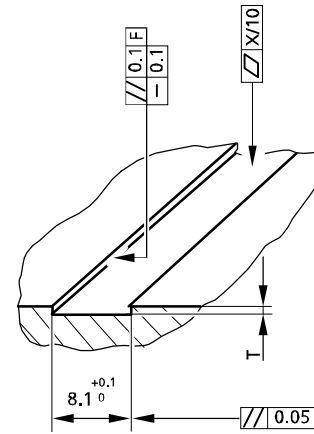

Fig. 2: Installation groove

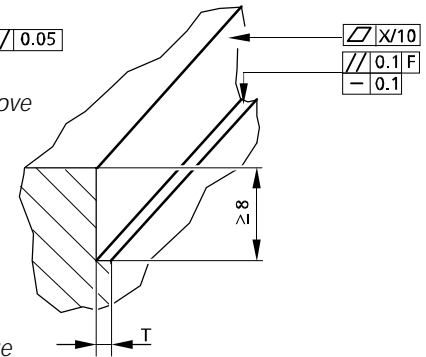

Fig. 3: Installation edge

Accuracy classes	X
1 μm	0.003
2 μm	0.006
3 μm	0.009
5 μm	0.009

Tape version	T
SINGLEFLEX	0.5
DOUBLEFLEX	0.7

F = machine guideway

These assume the function of a groove.

Grooves, stops or guide tapes are recommended for an DOUBLEFLEX tapes longer than 300 mm.

Counting direction

The counting direction of the system is positive (increasing measuring values) if the EPIFLEX measuring module opposite the scale tape moves in the direction shown in Fig. 21.

Cable

- If possible, mount the EPIFLEX measuring module on the rigid, and the scale tape on the mobile part of the machine. Otherwise, provide a strain relief for the connecting cable close to the connector board.



Caution!

There must be absolutely no relative movement between the EPIFLEX measuring module and the connector board.

- Connect the outside shield of the connecting cable with the machine's protective earth; at the side of the connector board the outside shield has been stripped and folded over the cable covering.
- The cables of the measuring system and the connecting cable must be laid away of interference sources (mains cables, fuses, motors, magnetic valves, power supplies); normally, a distance of 100 mm will be sufficient.

- When installing the measuring system in the machine, lay the cable so it cannot be damaged by the moving carriage.
- Make sure the cables' permissible bending radius r is not exceeded:

PUR round cable ($d = 5.3 \text{ mm}$)

bent once	$r \geq 11 \text{ mm}$
bent several times	$r \geq 26 \text{ mm}$
moving constantly	$r \geq 50 \text{ mm}$

Flat ribbon cable

bent several times over flat edge	$r \geq 5.5 \text{ mm}$
--------------------------------------	-------------------------

Extension cable

Use of original extension cable is recommended for optimum adaptation to the encoder and maximum resistance against electro magnetic interference.

Please consult the encoder manufacture before using a self-made cable.

It is to avoid absolutely to use the encoder cable for transmission other signals (non-encoder signals).

Electromagnetic compatibility (EMC)

Observe the following to ensure maximum protection against electrical and magnetic interference:

- Protect the EPIFLEX measuring module and the connector board against electric and magnetic interference fields by providing screening with good galvanic conductivity (metal or metalized housing/cover).
- Connect the housing/cover with the instrument's/machine's protective earth ensuring galvanic conductivity; if this is not possible (e.g. carrier component made of non-conductive material), provide a cable eyelet between the connector board and the screw head with a potential equalization line to the instrument's/machine's protective earth.
- Connect the connector board with the instrument's/machine's protective earth via the M2.5 mounting screw and the carrier component; if this is not possible (e.g. carrier component made of non-conductive material), provide a cable eyelet between the connector board and the screw head with a potential equalization line to the instrument's/machine's protective earth.
- If additional electronic units are used, mount the ZE housing to ensure good galvanic conductivity.
- If this is not possible, (e.g. on painted surfaces) connect the ZE housing by an additional potential equalization line (Cu line with cross section $\geq 6 \text{ mm}^2$) with the machine's protective earth.

- Please contact our service department or that of the appropriate manufacturer if you experience any problems when working with specific display or control units.

The Encoder Kit L conforms to the EN 50081-1, IEC 801-2 and IEC 801-4 regulations provided it is mounted and operated in accordance with these directives and the conditions given in these instructions.

(See also chapter 1, *Notes on safety*)

Connecting cables/connectors, pin assignment

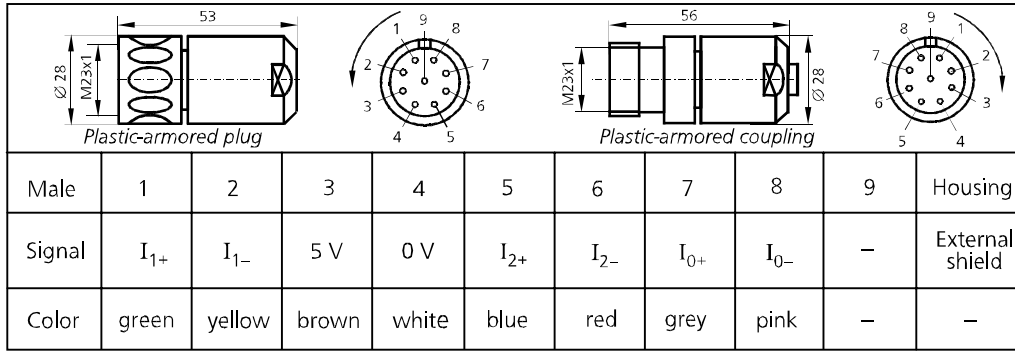

 $11 \mu A_{pp}$

Fig. 4:
Current interface $11 \mu A_{pp}$
9-pin connector
9-pin coupling
(male)

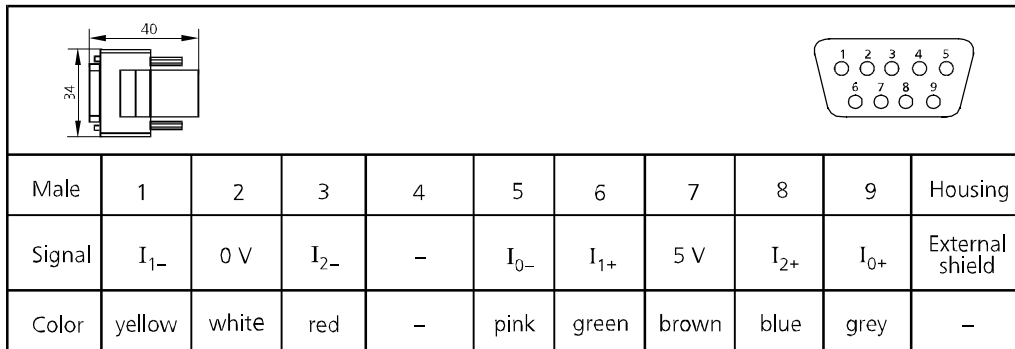

 $11 \mu A_{pp}$

Fig. 5:
Current interface $11 \mu A_{pp}$
9-pin D-sub connector
(male)

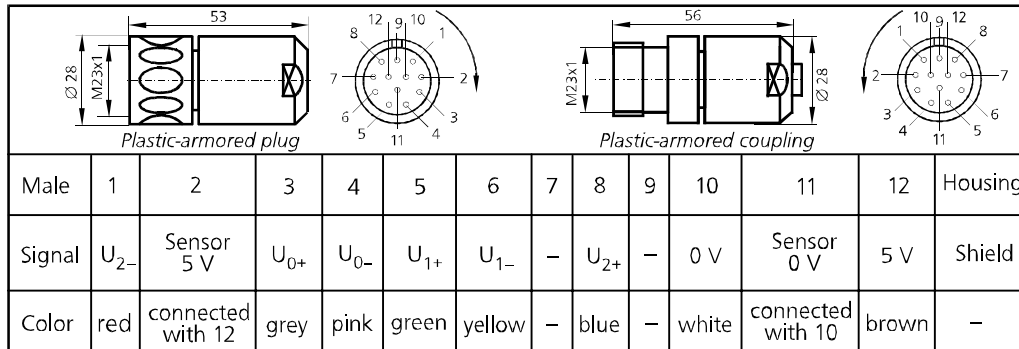

1 V_{pp}

Fig. 7:
Voltage interface 1 V_{pp}
12-pin connector
12-pin coupling
(male)



Male	1	2	3	4	5	6	7	8	9	Housing
Signal	U_{1-}	0 V	U_{2-}	–	U_{0-}	U_{1+}	5 V	U_{2+}	U_{0+}	External shield
	\bar{Z}_1	0 V	\bar{Z}_2	NAS	\bar{R}	Z_1	5 V	Z_2	R	
Color	yellow	white	red	violet	pink	green	brown	blue	grey	–

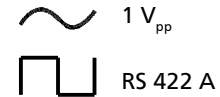
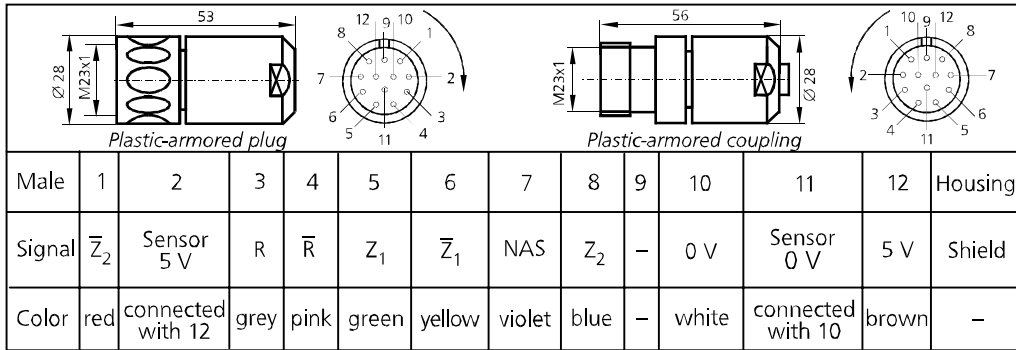

Fig. 9:
Voltage interface 1 V_{pp}
Square-wave interface
9-pin D-sub connector
(male)

NAS: negated monitoring
signal



 RS 422 A

Fig. 10:
Square-wave interface
12-pin connector
12-pin coupling
(male)

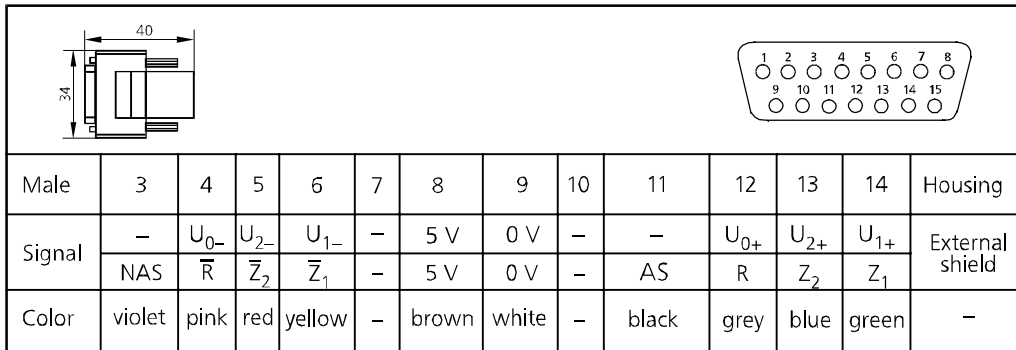

 1 V_{pp}

 RS 422 A

Fig. 11:
Voltage interface 1 V_{pp}
Square-wave interface
15-pin D sub connector
(male)
NAS: negated monitoring
signal
AS: monitoring signal

Recommended connection circuits

Circuit

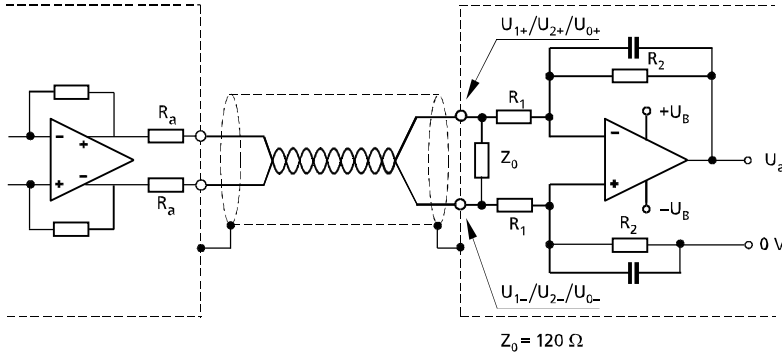

Signal curve

$1 V_{pp}$

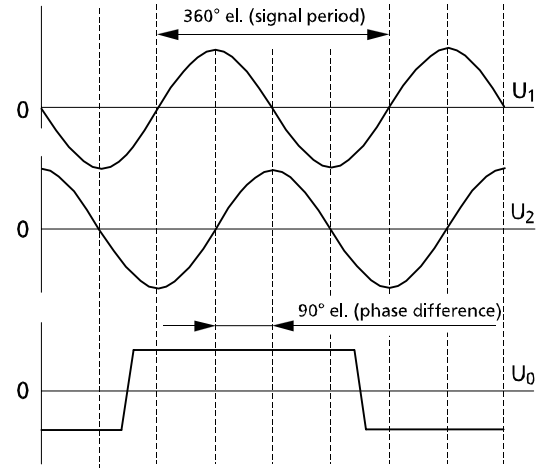

Difference signals measured on Z_0 :

$$U_1 = U_{1+} - U_{1-} = 0.6 \dots 1.2 V_{pp} \quad (\text{rated voltage: } 1 V_{pp})$$

$$U_2 = U_{2+} - U_{2-} = 0.6 \dots 1.2 V_{pp} \quad (\text{rated voltage: } 1 V_{pp})$$

$$U_0 = U_{0+} - U_{0-} = 0.5 \dots 1.2 V \quad (\text{rated voltage: } 0.8 V)$$

Fig. 12: Voltage output

Circuit

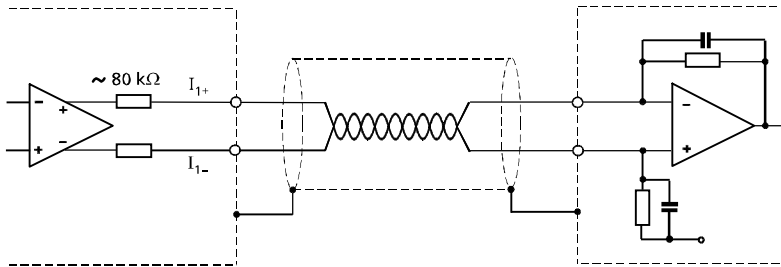

Signal curve

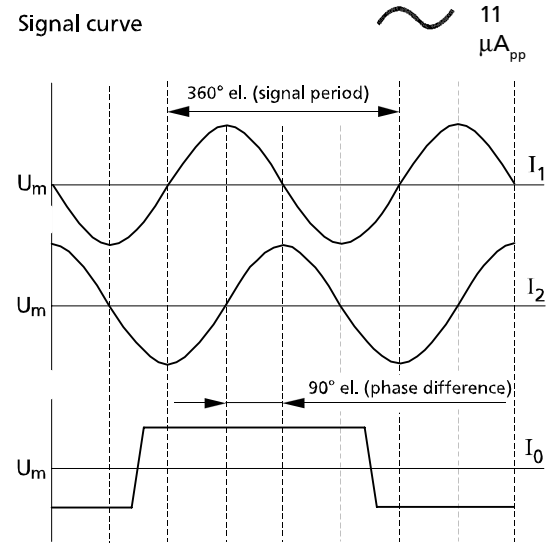

$$U_m = 2.5 \text{ V} \pm 0.5 \text{ V}$$

$$I_1 = 7.0 \dots 16 \mu\text{A}_{pp}$$

$$I_2 = 7.0 \dots 16 \mu\text{A}_{pp}$$

$$I_0 = 5.5 \dots 15 \mu\text{A}$$

Fig. 13: Current output

Circuit

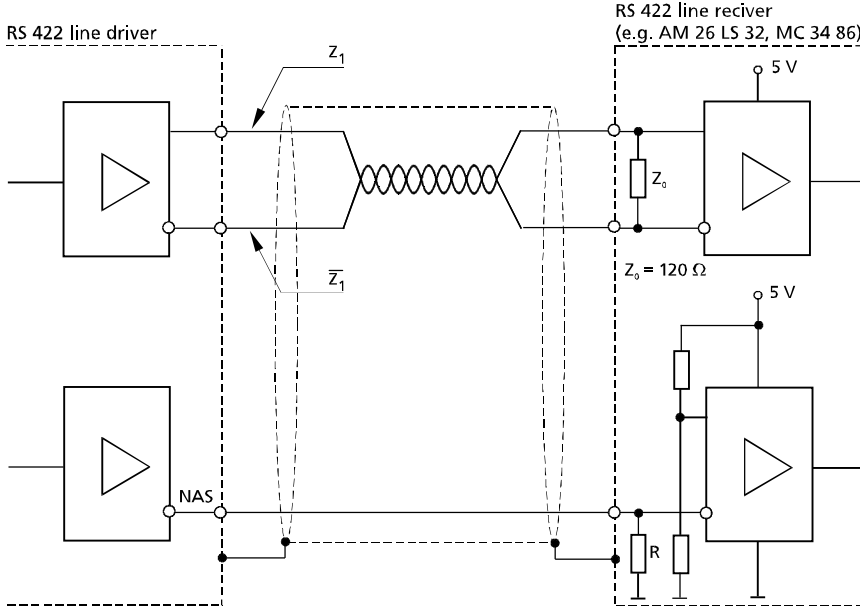

Signal curve

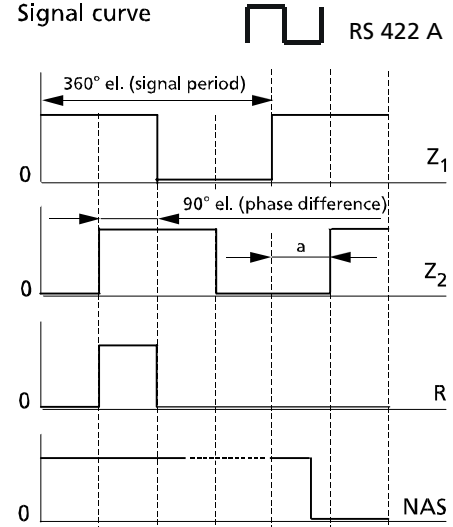

NAS high:
measuring system functioning;
input signals within tolerance range

NAS low:
measuring system in disorder

a:
minimum flank distance as a
function of interpolation factor and
travel speed (see table page 44)

For avoiding electro-magnetic interference the cable adaptation with a terminate resistor of 120 Ω is necessary. In case of connection more than one parallel signal inputs to the encoder output (for example linear motors with parallel connection to position controller, speed controller, excelleration controller) pay attention on a resulting terminate resistor of $Z_{0res} = 120 \Omega$.

Fig. 14: RS 422 A square-wave output

5.2 Installation of scale tape without using guide tapes

5.2.1 Requirements

- The mounting surfaces must be prepared according to the installation drawings
 - Groove (*Figs. 2/25 – pages 9/40*)
 - Stop edge (*Figs. 3/25 – pages 9/40*)
 - Flat surface (*Fig. 25 – page 40*)
- When the tape is installed without the use of a groove or stop edge, a suitable rigid stop at the side or end must be used (preferably at the fixed end of the DOUBLEFLEX scale tapes), e.g. a stop blocks or rails.
The stop must implement the position and tolerance of the stop edge as specified in *Figs. 3 and 25*.



Caution!

The stop must not be displaced during installation.

5.2.2 Installation of DOUBLEFLEX tapes (tapes as per MV 10... ordering key)

Preparations

- Use a solvent (e.g. acetone, methylated spirits) to clean the adhesion surfaces of the machine.



Caution!

Make sure that no alien elements are left on the adhesion surface.

When applying the scale tape, make sure that no alien elements can get between the scale tape and the base surface.

Alien elements between the tape and the base (machine component) cause local differences in the spacing between the scale and the EPIFLEX measuring module and may result in deficiencies of the Encoder Kit L and/or in measuring errors.

- Adhere to relevant protection rules when applying the adhesive.



Caution!

- Loctite 480 J is a quick-action adhesive on a cyanacrylic base; it sets when exposed to air and has a dropping time of 2 minutes.
- Loctite 480 J sticks skin and eye lids together within seconds.

- **Keep Loctite 480 J out of the reach of children.**
- **Do not inhale the adhesive and use it in well ventilated rooms only.**
- **Make sure to avoid skin and eye contact.**
- **If your skin has stuck together, soak it in warm soap water and then use a blunt object to carefully peel it apart.**
- **If eye contact has been made, rinse thoroughly with water and consult an ophthalmologist.**
- **Use water to set spilled adhesive.**
- **Store in a cool place at 5 °C.**

Procedure

(Fig. 15 – page 22)

- Use a scribing pin, for example, to mark the center of the bonding pad on the adhesion surface of the machine (6.3 mm from the end and 4 mm from the side of the DOUBLEFLEX scale tape).
Apply one drop of adhesive (epoxy resin or Loctite 480) on the marked spot.
- Peel off ~70 mm of the red protective film on the back of the carrier tape.



Caution!

The adhesive tape now exposed must not be brought into contact with other materials due to its strong adhesive force.

- Fold out the protective film toward the stop-free side beside the DOUBLEFLEX tape or the groove;
apply a drop of Loctite 480 and dip the bonding pad into this drop within ~2 minutes (= dropping time of adhesive).
- Place the bonding pad in the adhesive drop, at the same time sticking down the first ~ 50 mm of the DOUBLEFLEX scale tape.



Caution!

In the adhesive area (exposed adhesive tape) the DOUBLEFLEX scale tape must be positioned precisely against the stop on the machine component or in the groove.

- Carefully pull out the protective film sideways and press the scale tape against the adhesive surface of the machine component from the bonding pad in the direction of the tape end (using your thumb or a rounded object).
The pressure point should lie ~ 30 to 50 mm behind the line separating the adhesive tape and the protective film.



Note!

Make sure that the full length of the DOUBLEFLEX scale tape is lodged securely against the stop mechanism.

5.2.3 Installation of SINGLEFLEX scale tapes (tapes as per MV11... ordering key)

Preparations

- Use a solvent (e.g. acetone, methylated spirits) to clean the adhesion surfaces of the machine.



Caution!

Make sure that no alien elements are left on the adhesion surface.

When applying the scale tape, make sure that no alien elements can get between the scale tape and the base surface.

Alien elements between the tape and the base (machine component) cause local differences in the spacing between the scale and the EPIFLEX measuring module and may result in deficiencies in the Encoder Kit L and/or in measuring errors.

Procedure

(Fig. 16 – page 22)

- Peel off ~ 70 mm of the red protective film on the back of the carrier tape.



Caution!

The adhesive tape now exposed must not be brought into contact with other materials due to its strong adhesive force.

- Fold out the protective film toward the stop-free side beside the SINGLEFLEX tape or the groove.
- Place the scale tape with the end from which the protective film has been removed against the end and side stop mechanisms.
- Carefully pull out the protective film sideways and press the scale tape against the adhesive surface of the machine component (using your thumb or a rounded object). The pressure point should lie ~ 30 to 50 mm behind the line separating the adhesive tape and the protective film.



Note!

Make sure that the full length of the SINGLEFLEX scale tape is lodged securely against the side stop mechanism.

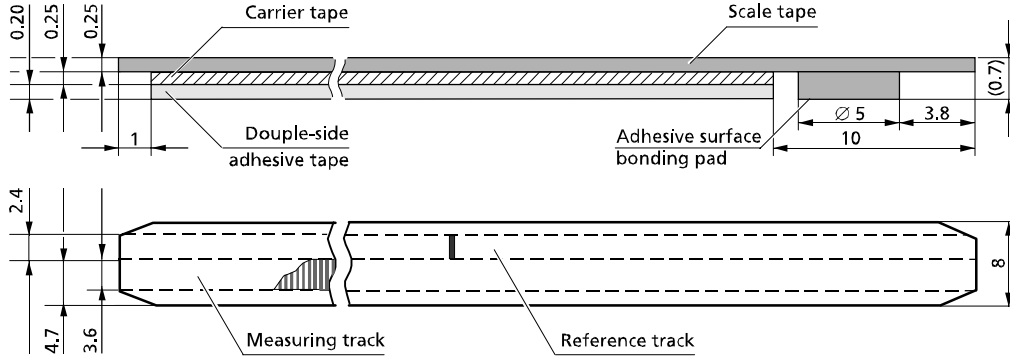

For measuring lengths exceeding 300 mm, a groove, stop rail or guide tape is required!

Fig. 15: DOUBLEFLEX scale tape

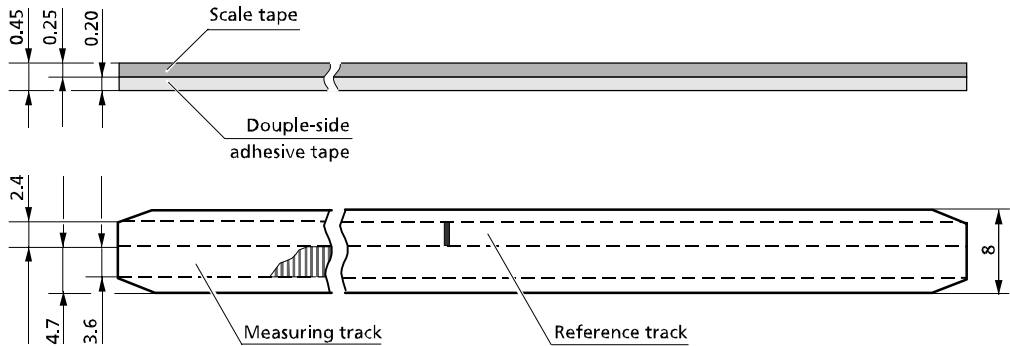

Fig. 16: SINGLEFLEX scale tape

5.3 Installation of scale tape using guide tapes (as per MV12 ...MV13 ordering key)

5.3.1 Requirements

- The seating surfaces have been prepared according to the installation drawing: flat surface (*Fig. 25 – page 40*).
- The guide tapes are equally suited for DOUBLEFLEX and for SINGLEFLEX scale tapes.
However, their thickness differs, as it has been adapted to the thickness of the scale tapes supplied:
DOUBLEFLEX scale tape $d = 0.7 \text{ mm}$
SINGLEFLEX scale tape $d = 0.5 \text{ mm}$
- Make sure that the guide tapes intended for DOUBLEFLEX scale tapes are not used for SINGLEFLEX scale tapes and vice versa.
- If the FAV guide tape mounting device is used for mounting the guide tapes, this should be done as shown in Fig. 26. The FAV can be screwed on the machine element or on an auxiliary fixture.
It is essential that the FAV is moved parallel (0.08) to the guiding direction of the machine carriage while the guide tape is being applied.
- If there is not enough room for the FAV, other means must be used (e.g. stops) to bring the guide tapes into the position shown in Fig. 25.

5.3.2 Mounting the guide tapes

Preparations

- Use a solvent (e.g. acetone, methylated spirits) to clean the adhesion surfaces of the machine.



Caution!

Make sure that no alien elements are left on the adhesion surface.

When applying the scale tape, make sure that no alien elements can get between the scale tape and the base surface.

Alien elements between the tape and the base (machine component) cause local differences in the spacing between the scale and the EPIFLEX measuring module and may result in deficiencies of the Encoder Kit L and/or in measuring errors.

Procedure

(Figs. 17 ... 20 – pages 27/28)

- If the timing bolt of the FAV guide tape mounting device is not in the position „off“, move it in a vertical position by turning it clockwise.
- Screw the FAV or the auxiliary fixture to the appropriate machine component; use spacer gauges to set a distance of 0.25 mm between the scale tape and the lower FAV side.
- Move the machine/instrument carriage to bring the FAV into position 1 (~ 150 mm to the right of the scale tape end) (Fig. 17).
- Slide the guide tapes from the right into the grooves of the FAV and push them to the intended end of the tape.
- Lift up guide tape 1 and peel off the protective film of the adhesive tape approx. 10 mm in the direction of the guide tape 2;
replace guide tape 1 on its support surface (Fig 18).
- Lift up guide tape 2, pull the protective film of guide tape 1 approx. 20 to 30 mm through under guide tape 2 and peel off the protective film of guide tape 2 approx. 10 to 20 mm forward at an angle;
replace guide tape 2 on its support surface (Fig. 19).
- Move the FAV with the carriage into position 2 (approx. 20 mm to the right of the tape end).
Peel off the protective films of both adhesive tapes until the right-hand edge of the FAV has been reached (Fig. 20).

- Move the timing bolt of the FAV into a horizontal position by turning it anti-clockwise through 90°;
spring force now presses the guide tapes against the support surface.
- Move the FAV with the carriage to the intended right-hand tape end, peeling off both protective films synchronously with the carriage/FAV motion until they are completely removed.
- Move the timing bolt of the FAV into a vertical position by turning it clockwise through 90°;
remove the FAV from the machine component;
press the right-hand ends of the guide tapes against the support surface, making sure not to displace them in sideways direction.

The guide tapes are now aligned and attached parallel to the carriage motion, in the specified position relative to the EPIFLEX measuring module's scanning window and at the required distance from each other.

**5.3.3 Mounting the DOUBLEFLEX scale tapes
(as per MV 10... ordering key)****Preparations**

- Prepare the adhesion surface in accordance with 5.3.2 (Mounting the guide tapes).
- Adhere to the relevant protection rules when applying the adhesive.

**Caution!**

- Loctite 480 J is a quick-action adhesive on a cyanacrylic base; it sets when exposed to air and has a dropping time of 2 minutes.
- Loctite 480 J sticks skin and eye lids together within seconds.
- Keep Loctite 480 J out of the reach of children.
- Do not inhale the adhesive and use it in well ventilated rooms only.
- Make sure to avoid skin and eye contact.
- If your skin has stuck together, soak it in warm soap water and then use a blunt object to carefully peel it apart.
- If eye contact has been made, rinse thoroughly with water and consult an ophthalmologist.
- Use water to set spilled adhesive.
- Store in a cool place at 5 °C.

Procedure

(Fig. 15 – page 22)

- Mark the center of the bonding pad (e.g. using a scribing pin) on the adhesive surface facing the machine (6.3 mm from the beginning and 4 mm from the side of the DOUBLEFLEX scale tape).
Apply one drop of adhesive (epoxy resin or Loctite 480 J) on this mark.

- Peel off approx. 70 mm of the red adhesive tape on the rear of the carrier tape.

**Caution!**

The adhesive tape now exposed must not be brought into contact with other materials due to its strong adhesive force.

- Fold the protective film out of the groove formed by the guide tapes; apply a drop of Loctite 480 J and dip the bonding pad into this drop within ~ 2 minutes (= dropping time of adhesive).
- Place the bonding pad in the adhesive drop, at the same time sticking down the first ~50 mm of the DOUBLEFLEX scale tape.

**Caution!**

Make sure that the DOUBLEFLEX scale is located in the groove in the adhesive area.

- Carefully pull out the protective film at an angle and press the scale tape against the adhesive surface of the machine component starting at the bonding pad and working in the direction of the tape end (using your thumb or a rounded object).
The pressure point should lie ~ 30 to 50 mm behind the line separating the adhesive tape and the protective film.

5.3.4 Mounting the SINGLEFLEX scale tapes (as per MV 10... ordering key)

Preparations

- Use a solvent (e.g. acetone, methylated spirits) to clean the adhesion surfaces of the machine.



Caution!

Make sure that no alien elements are left on the adhesion surface.

When applying the scale tape, make sure that no alien elements can get between the scale tape and the base surface.

Alien elements between the tape and the base (machine component) cause local differences in the spacing between the scale and the EPIFLEX measuring module and may result in deficiencies of the Encoder Kit L and/or in measuring errors.

Procedure

(Fig. 16 – page 22)

- Peel off approx. 70 mm of the red film protecting the adhesive layer on the rear of the carrier tape.



Caution!

The adhesive tape now exposed must not be brought into contact with other materials due to its strong adhesive force.

- Fold the protective film out of the groove formed by the guide tapes.
- Place that end of the scale tape from which the protective film has been removed against the front stop.
- Carefully pull out the protective film sideways and press the scale tape against the adhesive surface of the machine component (using your thumb or a rounded object). The pressure point should lie ~30 to 50 mm behind the line separating the adhesive tape and the protective film.

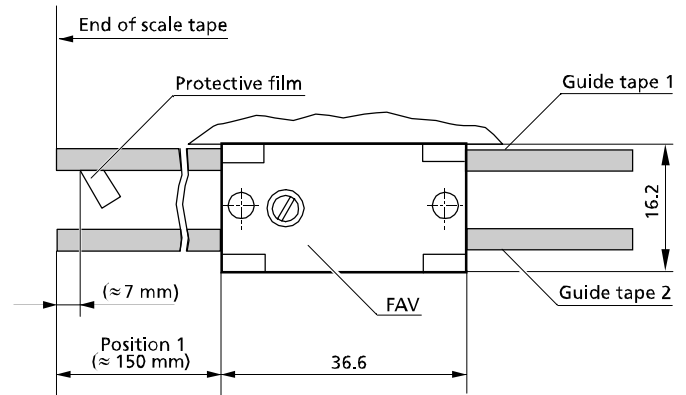
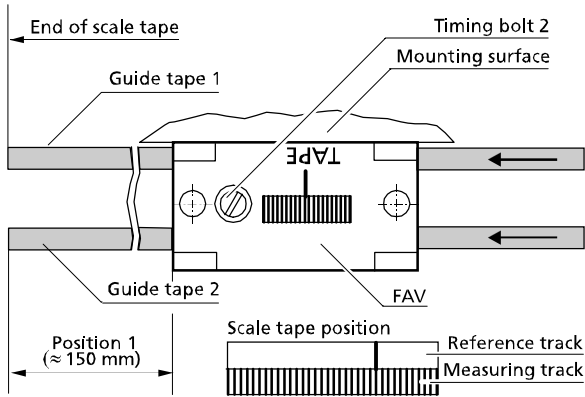
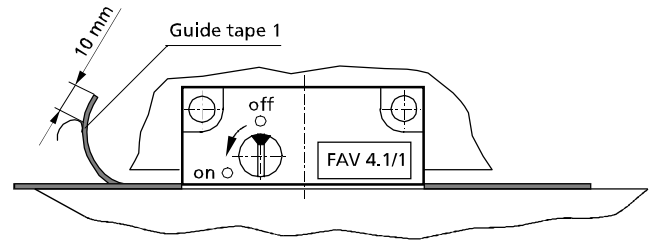
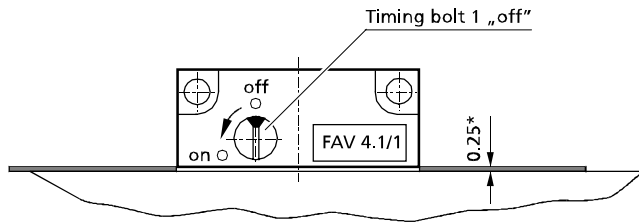

* It is recommended to use the FAV guide tape mounting device supplied.

Fig. 17: Mounting the guide tapes

Fig. 18: Mounting the guide tapes

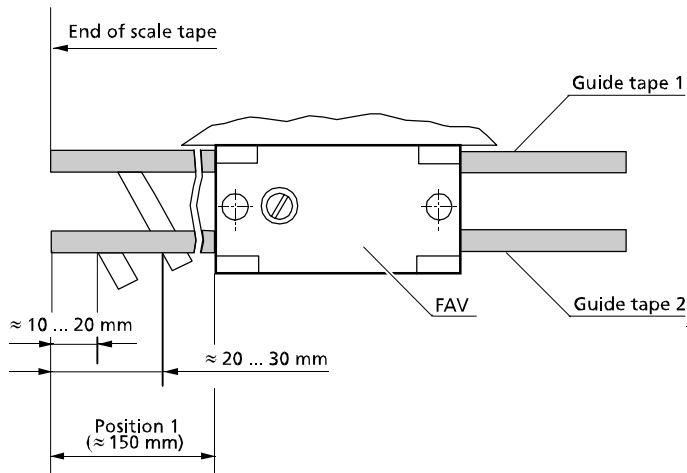
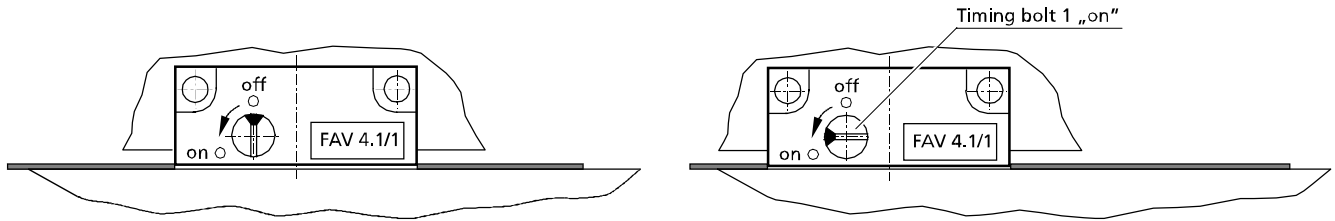

Fig. 19: Mounting the guide tapes

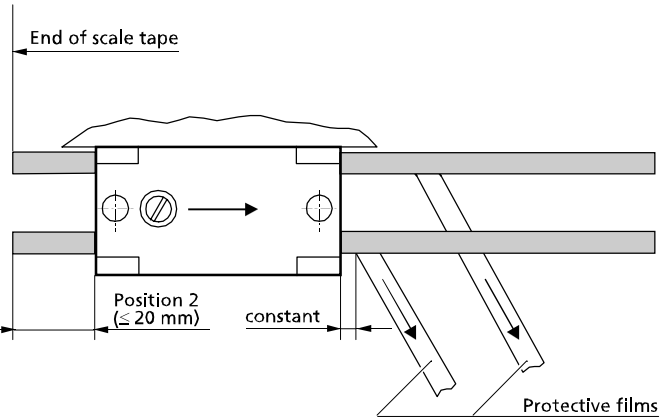

Fig. 20: Mounting the guide tapes

5.4 Mounting the EPIFLEX measuring module

Requirements

- The seating surface must be prepared according to the installation drawing (*Fig. 25 – page 40*)
- Please observe the installation conditions (see chapter 5.1)
- Depending on the length of the flexible tape PCB between the EPIFLEX measuring module and the connector board, the module will be mounted by means of a M2.5 screw and a groove or a clamp (*Fig. 24 – page 39*)



Caution!

Make sure that only the hatched area of the connector board (*Fig. 23 – page 36*) gets in contact with any other components; otherwise there is the risk of a short circuit.

- It is an advantage to disconnect the flexible tape PCB from the connector board before mounting the EPIFLEX measuring module; (for making and breaking the connections between the EPIFLEX measuring module and the connector board (*Fig. 23 – page 36*))

Preparations

- Remove the protective film from the graduated surface of the scale tape.
- Remove the protective film from the EPIFLEX measuring module.
- Carefully clean the surface of the EPIFLEX measuring module with a lint-free cloth, using a solvent (acetone, methylated spirits) if necessary. (see chapter 1.5, *Notes on maintenance*)
- Clean the seating surfaces on the machine component on which the EPIFLEX measuring module will be mounted.

Procedure

(*Fig. 25 – page 40*)

- Option 1:
Directly mount the EPIFLEX measuring module to the user's mechanical component using an adhesive.
- Option 2:
Preassemble the EPIFLEX measuring module on an auxiliary component (using adhesive) and then mount it.
In either case, the dimensions and tolerances for the positioning of the EPIFLEX measuring module and the scale tape (*Fig. 25*) must be observed.

- Stick the EPIFLEX measuring module on the narrow sides, using the contact face as basis for aligning the measuring module in the measuring direction (*Fig. 25 – page 40*). A two-component epoxy resin with a high filler content is recommended as adhesive agent.

**Note!**

Make sure that the adhesive is applied to the glass substrate and not to the sealing material.

- Use the spacer gauge supplied to set the correct distance between the scale tape and the EPIFLEX measuring module. For this purpose, insert the gauge between the EPIFLEX measuring module and the scale tape. During the mounting process, press the EPIFLEX measuring module lightly against the spacer gage and the scale tape.
- Carefully remove the spacer gauge after having attached the EPIFLEX measuring module.
- Connect the flexible tape PCB with the connector board (*Fig. 23– page 36*).
- Connect the connecting cable with the connector board.

- If a shielded round cable is used, connect the outside shield with the strain relief ensuring good galvanic conductivity. The strain relief must be connected to the protective earth of the machine/instrument.
- Carefully clean the scale tape surface (graduation) with a lint-free cloth, using a solvent (acetone, methylated spirits) if necessary. (see chapter 1.5, *Notes on maintenance*)
- Connect the cable with the following electronic unit taking into account the connector assignment.

**Caution!**

Make sure the electronic unit is switched off during connection, otherwise malfunctions or a breakdown may occur.

At a minimum, the measuring system would have to be readjusted.

- Switch on the evaluation electronics and perform a function test.

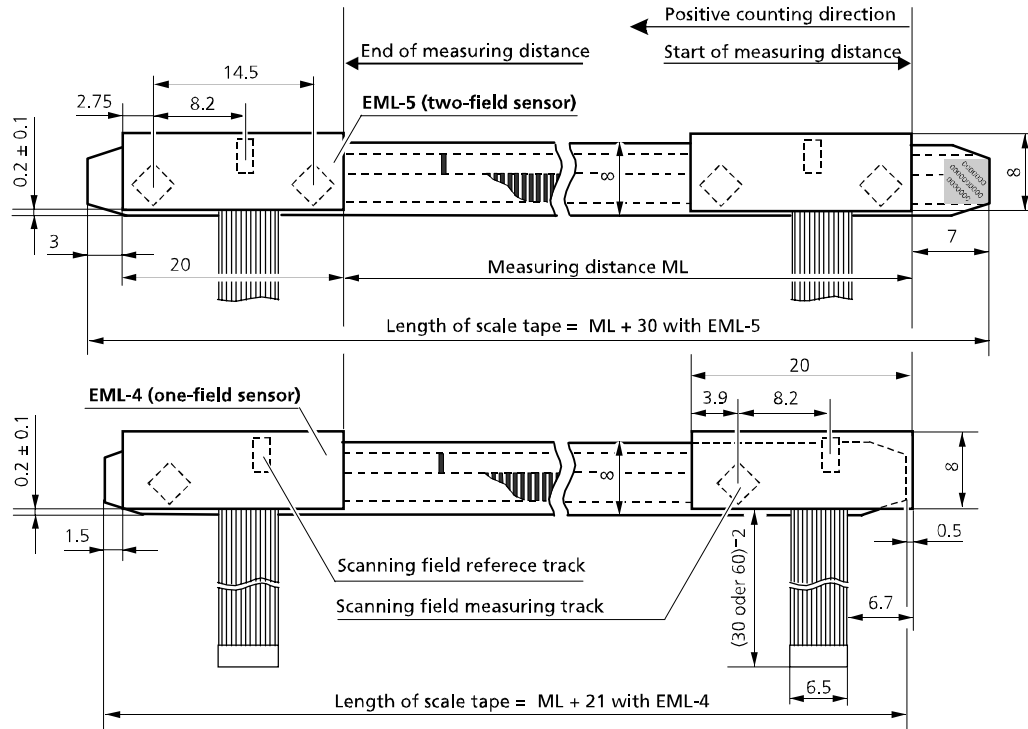
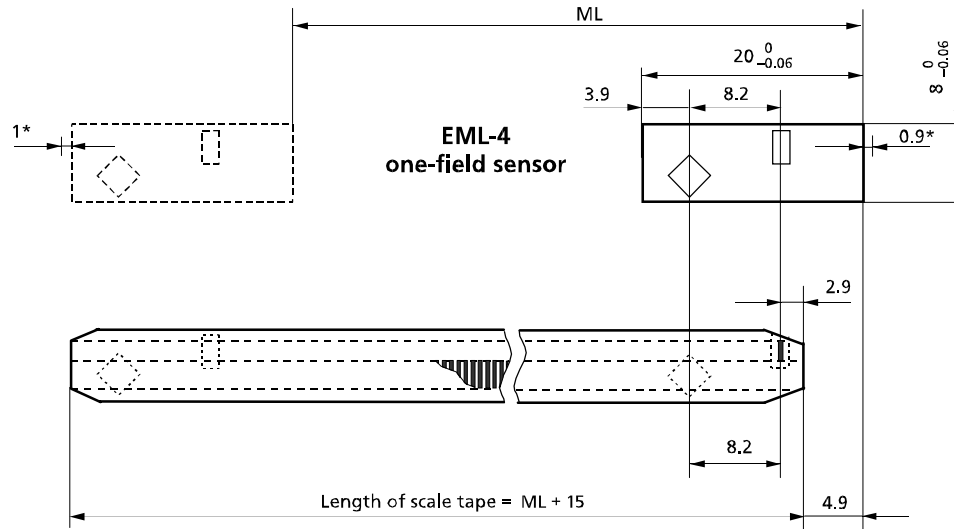
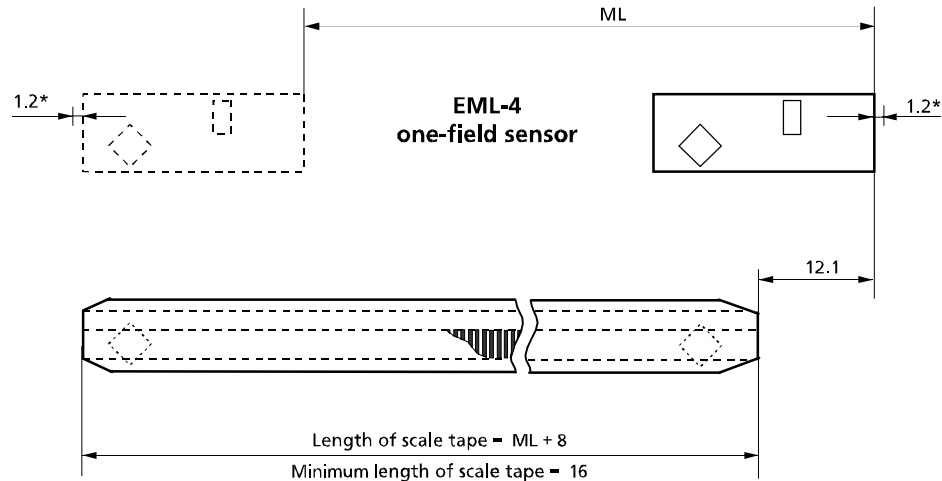

Fig. 21-1: EPIFLEX measuring module - relationship measured distance to scale tape – standard applies to SINGLEFLEX and DOUBLEFLEX scale tapes



*) max. overrun

Fig. 21-2: EPIFLEX measuring module - relationship measured distance to scale tape for **minimum** scale tape length EM-L4 **with** evaluation of reference mark applies only to SINGLIFLEX scale tapes



*) max. overrun

Fig. 21-3: EPIFLEX measuring module - relationship measured distance to scale tape for **minimum** scale tape length EM-L4 **without** evaluation of reference mark
applies only to SINGLIFLEX scale tapes

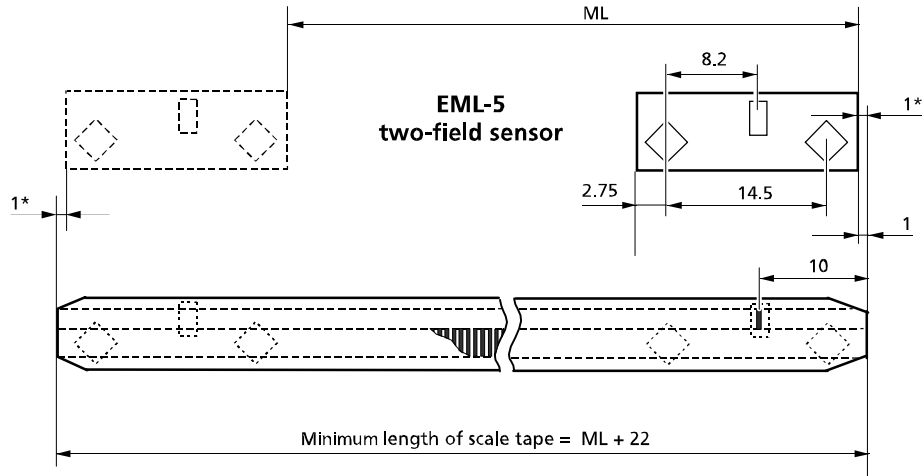

*) max. overrun

Fig. 21-4: EPIFLEX measuring module - relationship measured distance to scale tape for **minimum** scale tape length
EM-L5 **with** evaluation of reference mark
applies only to SINGLFLEX scale tapes

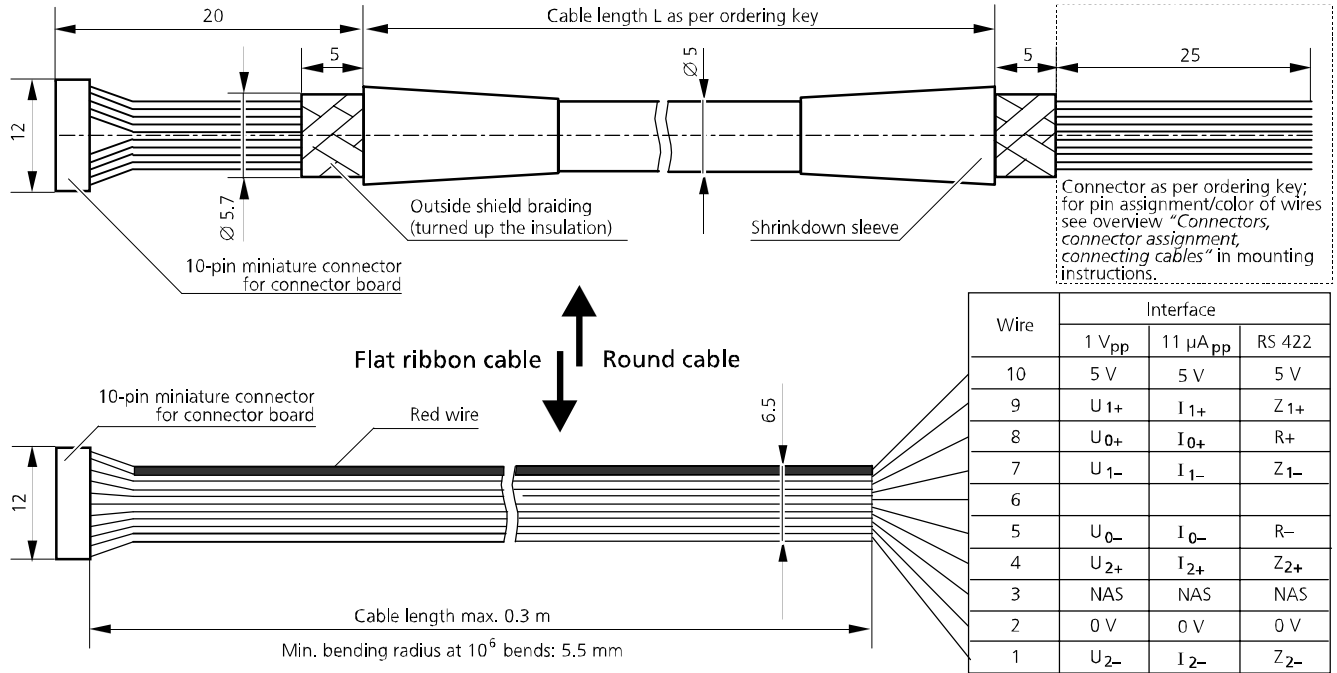

Fig. 22: Connecting cables

X₁: input connector board/output measuring module

PIN	1	2	3	4	5	6	7	8	9	10	11	12
sin 11 μA_{pp}	SCL	SDA	GND	CS	I_{1+}	I_{1-}	NAS	I_{0-}	I_{0+}	I_{2+}	I_{2-}	U_{B}
sin 1 V_{pp}	SCL	SDA	GND	CS	U_{1-}	U_{1+}	NAS	U_{0+}	U_{0-}	U_{2-}	U_{2+}	U_{B}

X₂: output connector board/input connecting cable

PIN	1	2	3	4	5	6	7	8	9	10
sin 11 μA_{pp}	I_{2-}	GND	NAS	I_{2+}	I_{0-}	-	I_{1-}	I_{0+}	I_{1+}	U_{B}
sin 1 V_{pp}	U_{2-}	GND	NAS	U_{2+}	U_{0-}	-	U_{1-}	U_{0+}	U_{1+}	U_{B}
RS 422 A	\bar{Z}_2	GND	NAS	Z_2	\bar{R}	AS	\bar{Z}_1	R	Z_1	U_{B}

X₃: testing and programming PINs

PIN		1	2	3	4	5	6	7	8
for signal interface (output connector board)	sin 11 μA_{pp}	SCL	SDA	–	–	–	–	CS	GND
	sin 1 V_{pp}	SCL	SDA	U_0 (Ref)	–	U_1 (sin)	U_2 (cos)	CS	GND
	RS 422 A without interpolation	SCL	SDA	U_0 (Ref)	GND	U_1 (sin)	U_2 (cos)	CS	GND
	RS 422 A with interpolation	SCL	SDA	U_0 (Ref)	U_M	U_1 (sin)	U_2 (cos)	CS	GND

Legend X_1, X_2, X_3

SCL	Serial clock for programming the measuring module
SDA	Serial data for programming the measuring module
CS	Chip select for programming the measuring module
GND	Mass (0 V)
I_{1+}, U_{1+}	sin signal counting track
I_{2+}, U_{2+}	cos signal counting track
I_{1-}, U_{1-}	- sin signal counting track
I_{2-}, U_{2-}	- cos signal counting track
I_{0+}, U_{0+}	Reference signal
I_{0-}, U_{0-}	- Reference signal
U_B	Operating voltage (+5 V)
Z_1	Counting signal 0°
Z_2	Counting signal 90°
\bar{Z}_1	Counting signal 0° negative (180°)
\bar{Z}_2	Counting signal 90° negative (270°)
R	Reference signal
\bar{R}	Reference signal negative
AS	Monitoring signal
NAS	Monitoring signal negative
U_M	Center voltage (+2.5 V)

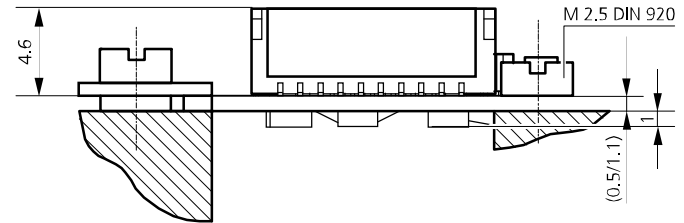

Fig. 24: Proposed mounting of connector board

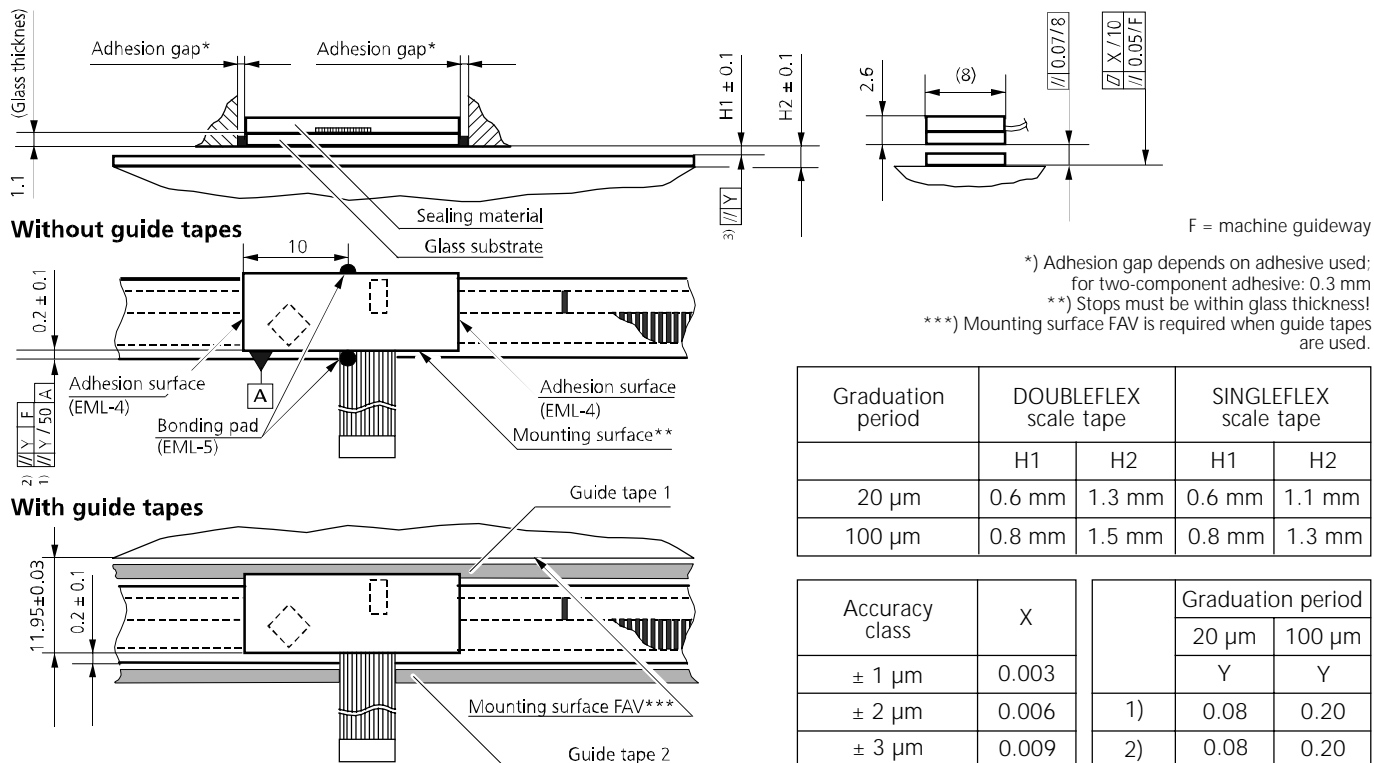

Fig. 25: Mounting specifications

Graduation period	DOUBLEFLEX scale tape		SINGLEFLEX scale tape	
	H1	H2	H1	H2
20 μm	0.6 mm	1.3 mm	0.6 mm	1.1 mm
100 μm	0.8 mm	1.5 mm	0.8 mm	1.3 mm

Accuracy class	X	Graduation period	
		20 μm	100 μm
$\pm 1 \mu\text{m}$	0.003	Y	Y
$\pm 2 \mu\text{m}$	0.006	1)	0.08
$\pm 3 \mu\text{m}$	0.009	2)	0.08
$\pm 5 \mu\text{m}$	0.009	3)	0.025

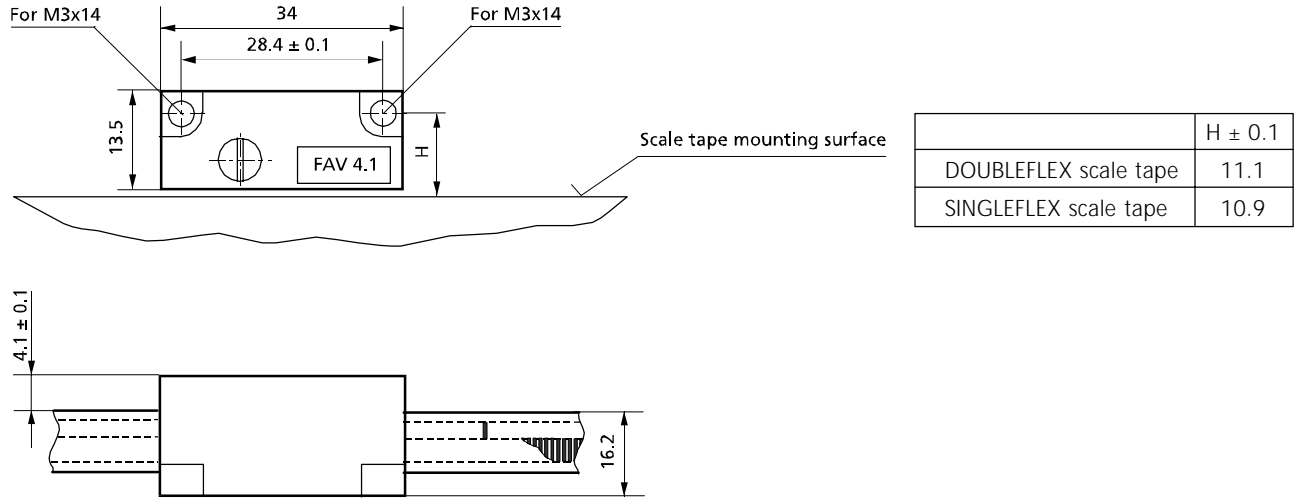

Fig. 26: Positioning scale tape – FAV

6 Technical specification

Resolution and accuracy (definition)

A difference must always be made between the resolution and the accuracy of a measuring system. The two parameters are not directly interdependent and may differ from each other.

Resolution

The resolution of a linear measuring system describes the least possible displacement of the scanning head against the scale which can still be discerned by the evaluation electronics (display, control).

It depends on (*see table 1*)

- the graduation period of the scale
- the signal interpolation factor (internally or in auxiliary electronic unit)
- the evaluation mode in the counter.

Accuracy

The accuracy of linear measuring systems is specified in accuracy classes.

The extreme error values for any max. one-meter section of the measured length lie within the specified accuracy class of $\pm a \mu\text{m}$ with respect to their mean value.

For measuring distances up to 1 m, the tolerance ($\pm a \mu\text{m}$) refers to the actual length measured.

The accuracy applies to a reference temperature of 20 °C. With open linear measuring systems, the definition of the accuracy class applies only to the scale. This is called scale accuracy.

Table 1

Graduation period of scale	Signal period of sinus signals	Interpolation factor	Signal period after interpolation	Resolution after evaluation in counter		
				1x	2x	4x
20 μm	20 μm	none 5x 10x 25x 50x	20 μm 4 μm 2 μm 0.8 μm 0.4 μm	20 μm 2 μm	10 μm 2 μm 1 μm 0.2 μm	5 μm 1 μm 0.5 μm 0.2 μm 0.1 μm

Mechanical data

DOUBLEFLEX scale tape	steel
Linear expansion coefficient	$\approx 10.5 \times 10^{-6} \text{ grad}^{-1}$
Graduation periods (GP)	20 μm ; 100 μm ; others on request
Accuracy classes	$\pm 1 \mu\text{m}$, $\pm 2 \mu\text{m}$; $\pm 3 \mu\text{m}$; $\pm 5 \mu\text{m}$
Measuring lengths	up to 30 m
Reference marks	periodically at intervals of 50 mm; distance coded at $1000 \times \text{TP}$; at the center of the measured length
Recommended increments	0.1 μm ; 0.2 μm ; 0.5 μm ; 1 μm ; 5 μm ; 10 μm
Dimensions of EPIFLEX measuring module	8 x 20 x 2.6 mm ³
Max. travel speed, depending on evaluation electronics	see table 2 Travel speed limitations caused by signal tolerances have already been taken into account in the table.

Table 2

Increment GP = 20 µm	5 µm	1 µm		0.5 µm		0.2 µm		0.1 µm	
Increment GP = 100 µm	25 µm	5 µm		2.5 µm		1 µm		0.5 µm	
Interpolation	none	5x		10x		25x		50x	
Max. travel speed GP = 20 µm	480 m/min	150 m/min	480 m/min	40 m/min	360 m/min	16 m/min	140 m/min	8 m/min	70 m/min
Max. travel speed GP = 100 µm	2400 m/min	750 m/min	2400 m/min	200 m/min	1800 m/min	80 m/min	700 m/min	40 m/min	350 m/min
Min. flank distance	0.6 µs	0.25 µs	28 ns	0.25 µs	28 ns	0.25 µs	28 ns	0.25 µs	28 ns
Min. clock frequency (of counter)	2 MHz	4 MHz	36 MHz	4 MHz	36 MHz	4 MHz	36 MHz	4 MHz	36 MHz

Electrical data	Scanning frequency	max. 400 kHz
	Output interfaces (output connector board)	
	– voltage output	1 V _{pp} with integrated line driver
	– current output	11 μA _{pp}
	– square-wave output	RS 422 A; optionally with internal signal interpolation 5/10/25/50x
	Supply voltage	5 V dc ± 10%
	Power consumption	
	– voltage output	< 50 mA
	– current output	< 30 mA
	– square-wave output (RS 422 A)	< 150 mA
Cable lengths		
– connecting cable (round cable) to scanning head	1 m with connector; other lengths on request; for greater lengths use extension cable	
– permissible cable lengths (with extensions)	max. 18 m for current output 11 μA _{pp} max. 100 m for voltage output 1 V _{pp} max. 100 m with square-wave RS 422 A	
Ambient conditions	Operating temperature range	0°C ... +55°C
	Storage temperature range	–20°C ... +70°C
	Vibration (50 Hz ... 2000 Hz)] Applies to components as such; if they are mounted as specified, these values can also be achieved with the components in mounted state.
	Shock (11 ms)	

Scale Tape

MV 1 0 - 1 0 B P 00770

Designation example

Material

1	Steel tape/one-field sensor
5	Steel tape/ two-field sensor

Design type

0	DOUBLEFLEX, standard
1	SINGLEFLEX, standard
2	DOUBLEFLEX, with guide tape
3	SINGLEFLEX, with guide tape
5	SINGLEFLEX min. length of scale tape with reference mark*
6	SINGLEFLEX min. length of scale tape without reference mark*

Accuracy class

1	± 1 µm
2	± 2 µm
3	± 3 µm
4	± 5 µm

Bonding pad position

0	none (SINGLEFLEX)
1	Start (DOUBLEFLEX)

Measuring length (ML) in mm

Graduation periods (GP)

P	20 µm
R	100 µm

Position of reference mark (RM)

O	none
B	RM in the center of measuring length
C	RM 35 mm from start of ML*
D	RM 35 mm from start of ML and 35 mm from end of ML *
E	Customized version *
F	RM distance coded at 1000•GP
N	RM at 50 mm spacings, starting at center of measuring length

E – specified in XXXXX mm from start of measuring length
 *) no standard, supplied against surcharge

**EPIFLEX measuring module,
linear measurement**

EML - 4 A P B 1

Designation example

Model type

EML	EPIFLEX measuring module, linear measurement
-----	---

Versions of EPIFLEX measuring module

4	One-field sensor
5	Two-field sensor

Frame

A	none	} on request
B	with frame of type B	
C	with frame of type C	
...	...	

Graduation periods GP

P	20 µm
R	100 µm

**Flexible tape PCB
length**

1	30 mm
2	60 mm

Output signals

B	Sinusoidal signal 11 µA _{pp}
C	Sinusoidal signal 1 V _{pp}
L*	Square-wave signal RS 422 A

*) applies only if the EPIFLEX measuring module is used without the connector board

length x width = 19 mm x 10.2 mm

Input-connector for flexible tape PCB to
EPIFLEX measuring module

Output-connector for connecting cable

Connector board

ALP	B	L	1
-----	---	---	---

Designation example

ALP	Connector board
-----	-----------------

Input signals
(Output signals EML)

B	Sinusoidal signal 11 μA_{pp}
C	Sinusoidal signal 1 V_{pp}

Output signals

B	Sinusoidal signal 11 μA_{pp}
C	Sinusoidal signal 1 V_{pp}
L	Square-wave signal RS 422 A with interpolation 5x
M	Square-wave signal RS 422 A with interpolation 10x
I	Square-wave signal RS 422 A with interpolation 25x
N	Square-wave signal RS 422 A with interpolation 50x
K	Square-wave signal RS 422 A without interpolation

*Min. signal input frequency [MHz] of evaluation
elektronics (without quad-edged evaluation);
specification necessary only for internal interpolation*

1	0.25
2	0.5
Y	0.75
3	1
Z	1.5
4	2
5	3
6	4
7	5
8	6
9	8
0	9

and for signal output B, C, K

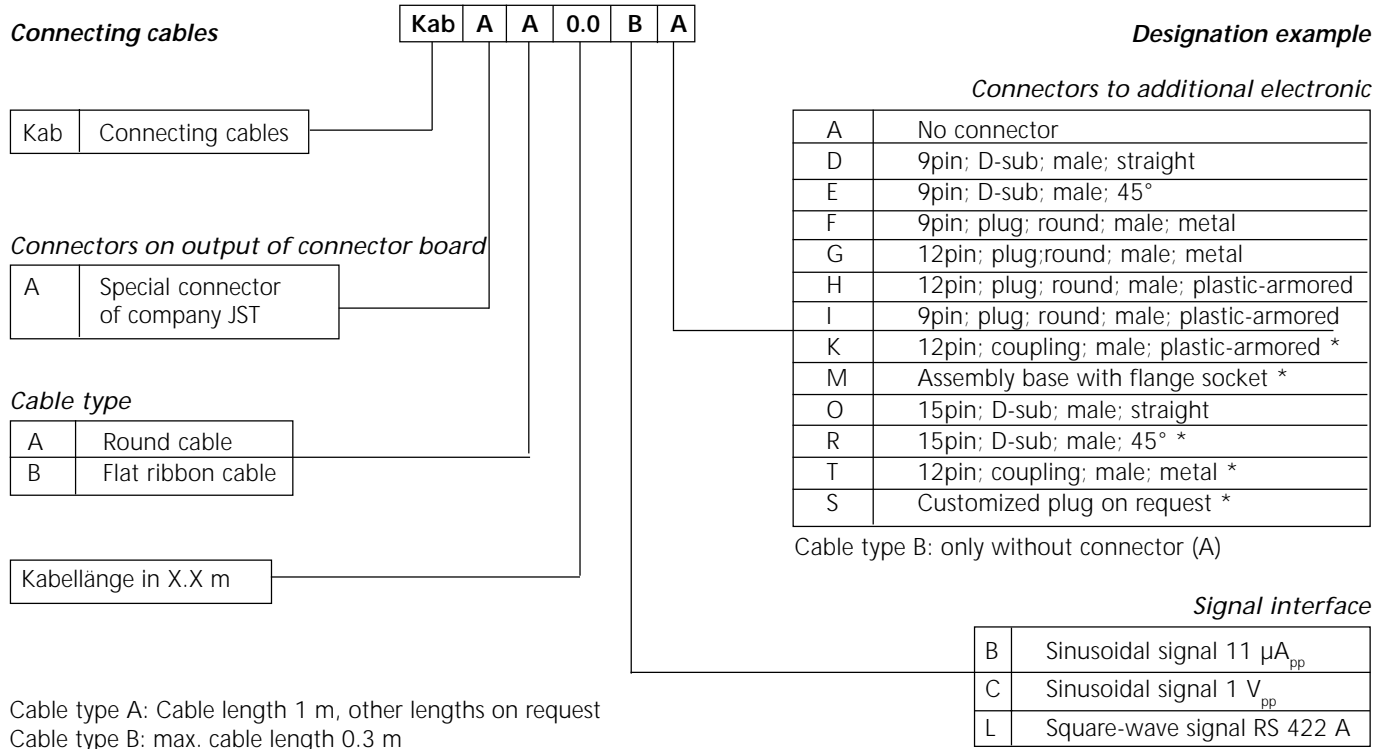

*) No standard, supplied against surcharge; see list of surcharges



NUMERIK JENA GmbH

Ilmstraße 4
D-07743 Jena
Germany

Telephone ++49 3641 47 28 21
Fax ++49 3641 47 28 20
E-mail info.nj@numerikjena.de
Internet www.numerikjena.de

Kit L-A-e-07/00

Subject to change without notice – 07/00